

TYPE 4 END IN/OUT SAME END

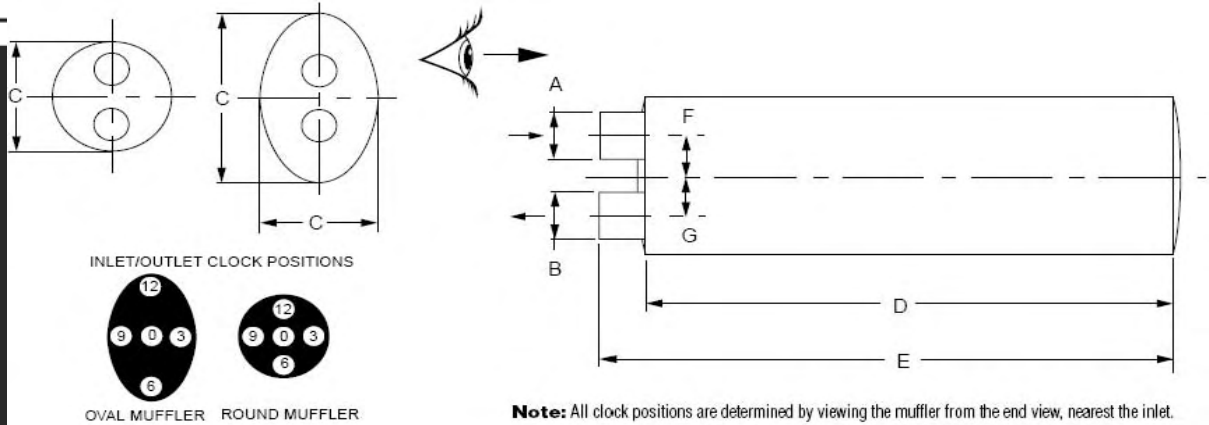

PART# NUMBER	A INLET SIZE	B OUTLET SIZE	C BODY SIZE	D BODY LENGTH	E OVERALL LENGTH	F INLET OFFSET	G OUTLET OFFSET	H INLET LENGTH	INLET CLOCK POSITION	OUTLET CLOCK POSITION
D14-0098	1.5"OD	1.5"OD	4.5	7.75	10.25	1.125	1.125	2.5	3	9
D14-0637	1.625"ID	1.5"OD	4.25X8.75	11	15	2.5	0	4	6	0
D14-0830	1.75"ID	1.5"ID	5	16	18	1.1875	1.1875	2	12	6
D14-0132	1.75"ID	1.5"OD	6	11	16	1.5	1.5	2.25	2	4
D14-0087	1.75"ID	1.5"OD	4.25X8.75	11	13	2.5	0	2	6	0
D14-0144	1.75"ID	1.5"ID	4.25X8.75	14	16.5	1.56	1.56	2.5	6	12
D14-0609	1.75"OD	1.75"ID	4.25X8.75	10	12	2.75	0	2.5	6	0
D14-0497	2"EL	2"OD	4.25X8.75	19	21.5	1	3	2	12	6
D14-0700	2"EL	2"ID	6x10	19	25.5	1"	3.4375	4.5	10:30	6
D14-1009	2"ID	2"ID	6	22	24.5	1.5	1.5	2.5	6	12
D13-1533	2"ID	2"ID	7	18	21.25	1.75	1.75	3.25	12	6
D14-0191	2"ID	1.5"OD	4.25X8.75	15.5	17.5	1.25	1.25	2	6	0
D14-0002	2"ID	1.625"OD	4.25X8.75	16	18.5	1.25	1.25	2.5	12	6
D14-0452	2"ID	2"ID	4.25X8.75	16	19	2	2	3	12	6
D14-0577	2"ID	1.625"OD	4.25X8.75	16	18.5	3	0.25	2.5	6"	0
D14-0471	2"ID	1.8"OD	4.25X8.75	18	20	1	3	2	12	6
D14-0029	2"ID	2"OD	4.25X8.75	19	21	2.5	2.5	2	6	12
D14-0080	2"ID	2"ID	4.25X8.75	19.5	22	0	2.5	2.5	0	6
D14-0927	2"ID	2"OD	5x10DW	19.875	22.5	1.5625	1.5625	2.5	12	6
D12-2020	2"OD	2"OD	6	12	14	1.5	1.5	2	12	6
D14-0178	2.5"ID	2.5"OD	7	12	13.5	1.875	1.875	1.5	6	12
D14-0592	2.5"ID	2.5"ID	7	20	21.5	1.625	1.625	1.5	9	3
D12-0112	2.5"ID	2.5"ID	4.5X11	28	30	3	3	2	12	6
D14-0570	2.75"OD	2.75"OD	9	9.5	12	1.75	2.375	2	7:30	10:30
D13-0143	3"ID	3"ID	8	18	21	2	2	2.5	12	6
D14-0161	3"ID	3"ID	8	29.5	33	2	2	3.5	9	3
D14-0650	3"ID	3"ID	8.5	28	31.5	2.25	2.25	3	12	6
D13-4289	3"ID	4"ID	10	29.5	33.5	H/V	H/V	3	6	12
D14-0698	3"ID	3"ID	11	28.5	32	3	3	3	6	12
D13-1529	3"ID	4"ID	10x15	30	36.25	2.5	3	6.25	12	6
D13-1128	3.5"FL	3"FLR	16	22	24	See	SEE	2	8	7
D13-0068	3.5"ID	4"ID	10x15	26	29.5	4.125	4.125	3.5	6	12

TYPE 4 END IN/OUT SAME END

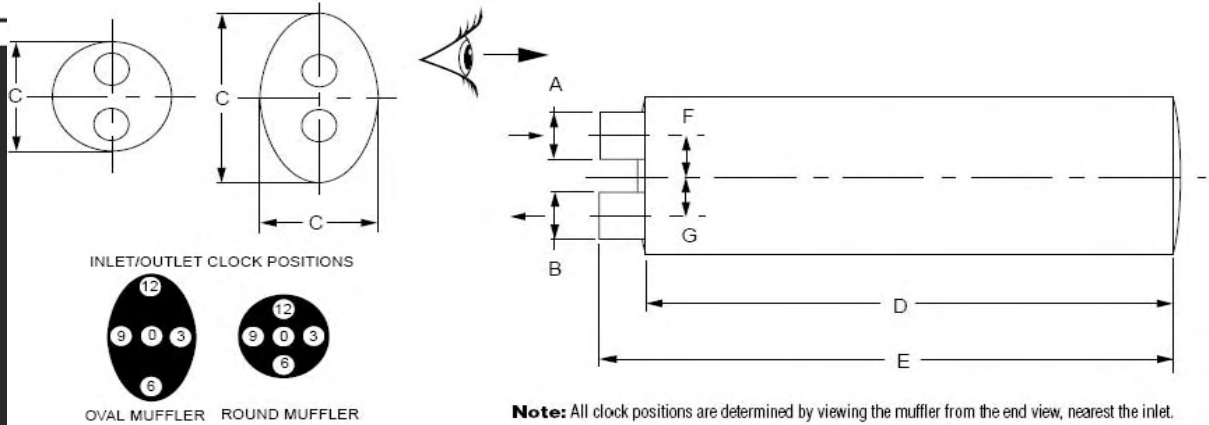

PART# NUMBER	A INLET SIZE	B OUTLET SIZE	C BODY SIZE	D BODY LENGTH	E OVERALL LENGTH	F INLET OFFSET	G OUTLET OFFSET	H INLET LENGTH	INLET CLOCK POSITION	OUTLET CLOCK POSITION
D13-1039	3.5"ID	3.5"OD	8.25X11.5	20	24	2.5	2.5	4	12	6
D99-0072	3.5"ID	4"OD	8.25X11.5	26.5	30	3	3	3.5	12	6
D13-1161	3.5"ID	4"ID	8.25X11.5	30.5	34	2.625	2.625	3	12	6
D13-1093	3.5"ID	4"ID	8.25X11.5	32	35.5	2.5	2.5	3.5	12	6
D14-0074	3.725"F	4"ID	10x15	16	19	4.25	4.25	3	6	12
D13-4288	4"ID	4"ID	10	26.5	31	2.4	2.4	3.5	6	12
D13-1534	4"ID	4"ID	10	28	31	2.4	2.4	3	6	12
D14-0007	4"ID	5"ID	10x15	16.5	20	4	4	3.5	6	12
D14-0862	4"ID	5"ID	10x15	19	22.5	4.25	3.58	3.5	6	12
D13-2006	4"ID	4"ID	10x15	26	29.2	4	4	3.2	12	6
D99-0163	4"ID	4"ID	10x15	26	29.5	4	4	3.25	12	6
D13-2071	4"ID	5"ID	10x15	27	31	4.4	4.4	4	12	6
D99-0164	4"ID	4"ID	10x15	27.5	31	1.75	4.25	3.5	12	6
D13-1092	4"ID	4"ID	10x15	36	39.5	4.5	1.5	3.5	6	12
D13-7741	4"ID	4"ID	10x15	36	39.5	0.5	4.5	3.5	12	6
D14-0163	4"ID	5"ID	10x15	44	47.5	4	4	3.5	6	12
D13-0124	4"ID	5"ID	12x15	30	34.5	1.5	4.5	4.5	12	6
D14-0031	4"ID	4.125"OD	8.25X11.5	26.5	30	2.5	2.5	3.5	6	12
D14-0679	4"ID	4.125"OD	8.25X11.5	26.5	30	2.5	2.5	3.5	6	12
D99-0028	4"OD	4"ID	10	26.5	33			5	6	12
D14-0433	4.59"ID	5"ID	10x15	26.5	30.5	4.5	3.5	3.5	6	12
D14-0018	4.59"ID	5.125"OD	10x15	27	42.625	4.5	3.5	3.5	6	12
D14-0511	5"F	5.125"OD asp	10x15	18	23.25	3.5	3.5	4.25	6	12
D14-0045	5"F	5.125"OD asp	10x15	19	23.5	3.5	3.5	2.75	12	6
D14-1007	5"ID	5"ID	12	35	38.5	3	3	3.5	12	6
D14-1013	5"ID	5"ID	12	38	41	3	3	3	6	12
D14-1003	5"ID	5"ID	12	41	44			3	12	6
D13-0094	5"ID	5"ID	12	44	47.5	3	3.5	3.5	6	12
D13-2011	5"ID	5"ID	10x15	26	29	3	3	3	12	6
D14-0109	5"ID	5"ID	10x15	26	29.5	3.25	3.25	3	6	12
D14-0122	5"ID	5"ID	10x15	26	29.5	3.5	3.5	3	6	12
D13-1105	5"ID	5"ID	10x15	36	39.5	3.75	3.75	3.5	6	12

mufflers

TYPE 4 END IN/OUT SAME END

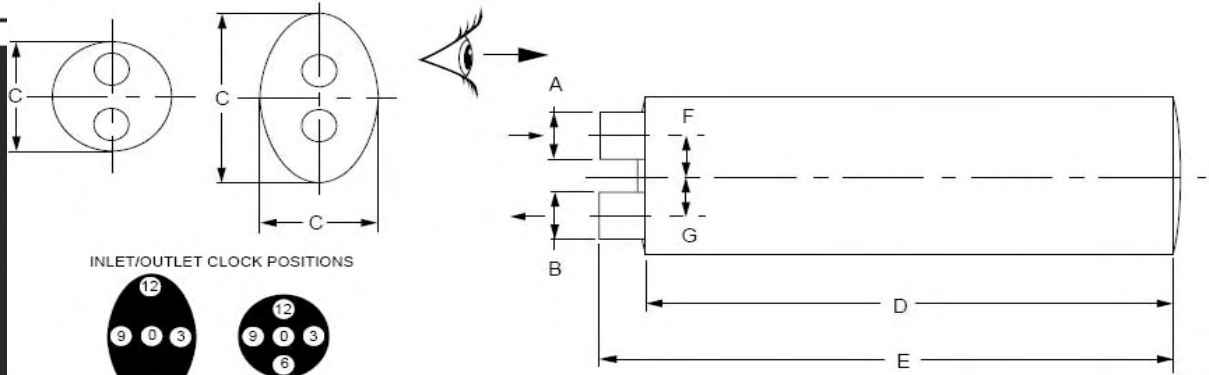

Note: All clock positions are determined by viewing the muffler from the end view, nearest the inlet.

PART# NUMBER	A INLET SIZE	B OUTLET SIZE	C BODY SIZE	D BODY LENGTH	E OVERALL LENGTH	F INLET OFFSET	G OUTLET OFFSET	H INLET LENGTH	INLET CLOCK POSITION	OUTLET CLOCK POSITION
D13-2007	5"ID	5"ID	10x15	36	39	4	4	3	6	12
D14-0188	5"ID	5"ID	10x15	36	39.5	4	4	3	6	12
D14-0681	5"ID	6"EL	10x15	40	50ish	3.125	3.625		6	12
D13-0102	5"ID	5"ID	10x15	44	47.5	3.5	3.5	3.5	6	12
D13-1053	5"ID	5"ID	10x15	44	47	3.5	3.5	3	12	6
D13-2090	5"ID	5"ID	10x15	44	47.5	4	4	3.5	12	6
D13-2078	5"ID	5"ID	12x15	36	39	?	?	?	?	?
D13-7711	5"ID	5.1"ID	12x23	22.5	26.5	4	1.5	3.5	5	10
D13-7714	5"ID	4.35"OD	12x23	23.5	27	5.6	2.5	3.5	11	3
D14-0458	5"OD	5"OD	10x15	32.5	36	3.5	3.5	3.5	12	6
D14-0210	6"ID	6"ID	16	30	34.5	4	4	4.5	12	6
D14-0603	6"ID	5"ID	10x15	39	42.5	3.5	4	3.5	12	6
D13-1550	6"ID	6"ID	10x15	40	44	3.75	3.75	3.25	12	6