

mufflers

TYPE 10
SIDE IN
SIDE OUT

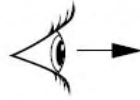

Note: All clock positions are determined by viewing the muffler from the end view, nearest the inlet.

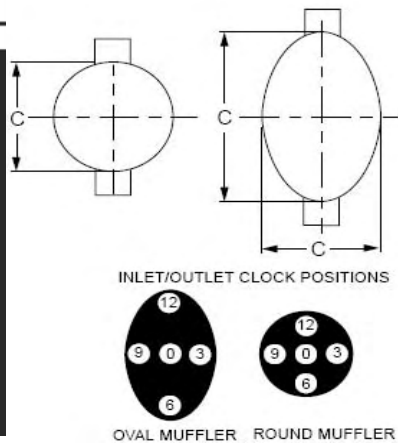
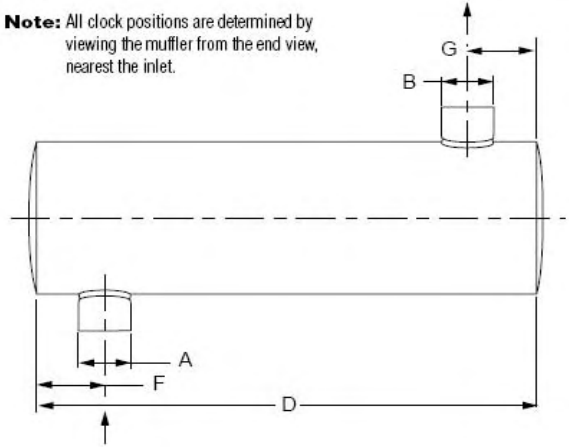

PART# NUMBER	A INLET SIZE	B OUTLET SIZE	C BODY SIZE	D BODY LENGTH	E OVERALL LENGTH	F INLET OFFSET	G OUTLET OFFSET	H INLET LENGTH	INLET CLOCK POSITION	OUTLET CLOCK POSITION
D14-0671	2.625	4"TP	9	23.75	23.75	3.75	3	3.5	2:45-9:15	12
D14-0845	0.875"ID	1"OD	5	13	13	1.5	6.5	1.5	3	12
D14-0459	1"ID	1"NPT	3	10	10	1.375	1.375	1.25	12	3
D14-0134	1.25"ID	1.25"ID	6	15	15	1.625	1.375	1.25	12	12
D14-0610	1.5"ID	1.5"ID	5	11	11	2	1.75	2	12	4:30
D14-0726	1.5"ID	1.5"ID	5	16.25	16.25	1.875	1.875	1.5	12	6
D14-0739	1.5"ID	1.5"ID	5	16.5	16.5	3.25	1.625	1.25	12	4:30
D14-0173	1.5"ID	1.5"OD	6	16	16	2	2	3.5	6	12
D14-0720	1.75"EL	1.625OD	6	12	12	1.75	2	2	12	9
D14-0933	1.75"ID	1.75"OD	5	14	14	2.5	12.675	2.75	6	12
D14-0052	1.75"ID	2"ID	5	15	15	1	1.125	2	6	1
D14-0051	1.75"ID	1.75"ID	5	17	17	2	2	2	12	6
D14-0651	1.75"ID	1.625"OD	6	11.875	11.875	2	3.625	3	12	2:30
D14-0044	1.75"ID	2"OD	6	17	17	1.625	1.5	2	6	1
D12-2027	1.75"ID	0.5" PIPE	7	16	16	2.5	3.25	2.5	12	7:30
D14-0587	1.75"OD	1.75"OD	5	20	20	3	3	2	6	12
D14-0722	1.75"OD	2.25"OD	6	29.5	29.5	2.75	3.25	2	12	7
D14-0498	1.75"OD	1.75"OD	4.25X8.75	12	12	1.75	1.75	3	3	9
D14-0088	1.875"ID	2.5"OD	4.25X8.75	24	24	2--5	2.5	1.75	12	3
D14-0738	2"F	2"OD	7	24	24	7.5	4	3	6	12
D14-0942	2"ID	2"ID	4	30	30	6.5	5.5	2.5	6	2
D14-0711	2"ID	1.875"OD	4.5	19	19	1.5	7.25	1.5	12	12
D14-0797	2"ID	2"ID	5	18.5	18.5	2	5.5	2.5	6	12
D13-1506	2"ID	2"ID	5	20	20	2.5	2.5	2.5	12	3
D14-0669	2"ID	2"ID	5	23.5	23.5	2	2.5	2	2:30	12
D14-0638	2"ID	2"ID	6	20.5	20.5	2.5	2.5	2.75	12	9
D14-0678	2"ID	2"ID	6	21.5	21.5	2	2	1.625	12	10
D14-0967	2"ID	2.1"OD	6	26.5	26.5	2	2	2.5	12	6
D14-0706	2"ID	2"ID	8	22	22	7.5	3.25	2.25	6	12
D14-0127	2"ID	2.5"OD	8	23.5	23.5	2.5	5.5	2.75	12	3
D14-0636	2"ID	2.5"TP	8	23.5	23.5	2.5	5	2	9	12

mufflers

TYPE 10
SIDE IN
SIDE OUT

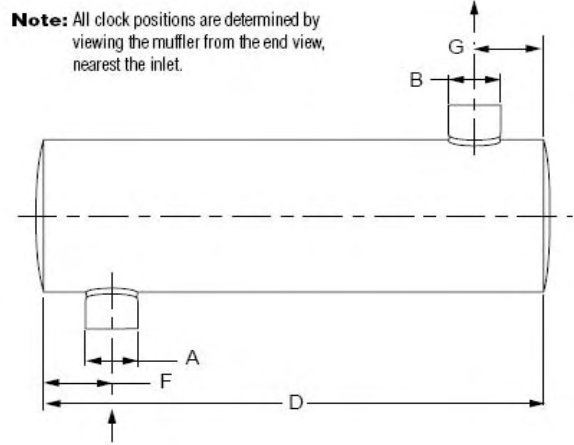
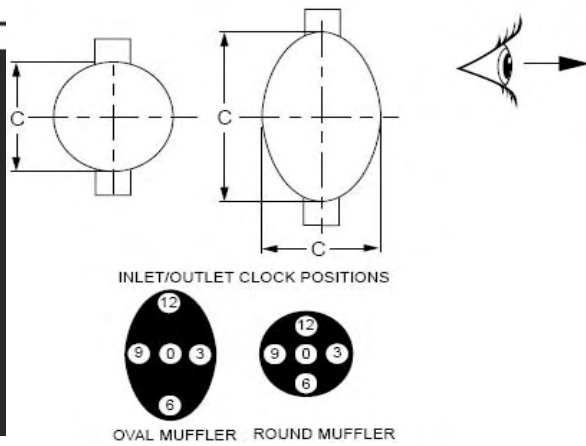

PART# NUMBER	A INLET SIZE	B OUTLET SIZE	C BODY SIZE	D BODY LENGTH	E OVERALL LENGTH	F INLET OFFSET	G OUTLET OFFSET	H INLET LENGTH	INLET CLOCK POSITION	OUTLET CLOCK POSITION
D14-0269	2"ID	2.25"ID	8	25	25	2.5	2.375	2.5	2	12
D14-0820	2"ID	2"ID	8.5	15.625	15.625	5.312	2"ID	1.5	1--5	5
D14-0228	2"ID	2.25"OD	8.5	20.5	20.5	2.875	3	3.5	6	4
D14-0181	2"ID	2"OD	4.25X8.75	18	18	4	4	2	9	3
D14-0253	2"ID	3"ID	8.25X11.5	14.75	14.75	2.75	3	2.5	1--11	8--4
D14-0798	2"OD	2"ID	4.5	19.5	19.5	2	2	2	12	9
D12-0100	2"OD	2"OD	6	20	20	4	4	3	3	6
D14-0960	2"OD	2"OD	7	17.5	17.5	2	3.75	2	3	12
D14-0472	2"OD	2.5"OD	7	24	24	4.25	7	3	1	12
D13-1587	2"OD	2"ID	8	17.5	17.5	2.5	2.5	3	12	6
D14-0589	2"OD	2.5"OD	8	24.375	24.375	4	2.75	3	11	6
D14-0241	2"OD	2.5"OD	8.5	21	21	3	3	3	6	10:30
D14-0980	2"OD	3"ID	10	25	25	6	3	4	12	11
D14-0164	2.25"ID	2.25"ID	8	18	18	2.5	2.5	3	11	5
D14-0037	2.25"ID	2.5"ID	8	21.75	21.75	3.875	4	2	6	12
D14-0550	2.25"ID	2.25"ID	8	22	22	4	4	2	6	12
D14-0987	2.25"ID	4"OD	10	27	27	4.5	4	3	12	7:30
D14-0626	2.25"OD	2.25"OD	9	20.5	21	3.875	2.875	1.5	6	12
D14-0825	2.36"OD	3"ODTP	10	25.5	25.5	4	4.25	3	2	12
D14-0932	2.375"ID	2.5"F	6	19	19	4.25	3.5	2.5	5	1--5
D14-0283	2.375"ID	2.5"OD	7	20	20	2.5	2.5	2.5	7	12
D14-0773	2.375"ID	2.5"OD	7	21.5	21.5	2.5	2.5	2.5	6	12
D14-0985	2.375"ID	2.5"ODEL	7	24.25	24.25	2.375	2.375	1	12	2
D14-0130	2.375"ID	3.5"TP	10	23.75	23.75	2.875	2.875	3	3	12
D14-0192	2.375"ID	2.5"OD	4.5X11	21.5	21.5	6	2	3	4--8	10--2
D14-0563	2.42"EL	2.5"TP	10	25	25	2	2.5	4	11	12
D14-0500	2.42"ID	3.5"OD	10	25.5	26	4	4	3.5	2:30	12
D14-0928	2.5"EL(id)	3"OD	10	25.5	25.5	3.5	4	3.5	2	12
D14-0126	2.5"F	3"TP	10	23.5	23.5	3.75	3	1.5	7	12
D14-0799	2.5"F	2.25"ID	4.25X8.75	24	24	1.75	1.75	6.5	2:30	4"
D14-0071	2.5"ID	2"OD	6	19.5	19.5	3	2	2.5	12	9

mufflers

TYPE 10
SIDE IN
SIDE OUT

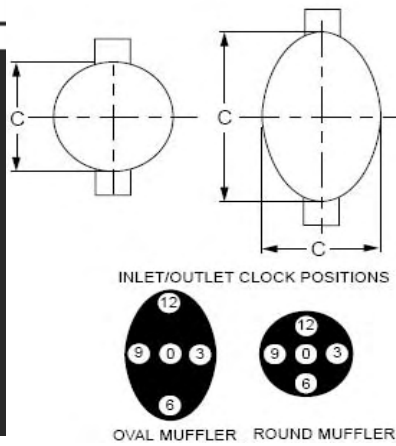

Note: All clock positions are determined by viewing the muffler from the end view, nearest the inlet.

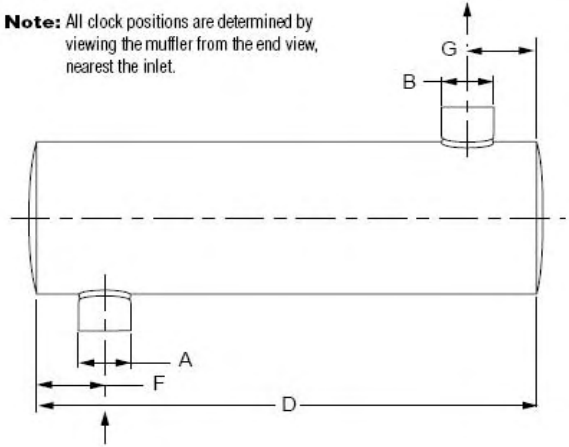

PART# NUMBER	A INLET SIZE	B OUTLET SIZE	C BODY SIZE	D BODY LENGTH	E OVERALL LENGTH	F INLET OFFSET	G OUTLET OFFSET	H INLET LENGTH	INLET CLOCK POSITION	OUTLET CLOCK POSITION
D14-0547	2.5"ID	2"OD	6	19.5	19.5	2.75	1.5	3	12	3
D14-0654	2.5"ID	2.5"ID	6	24	24	12	2	3	6	12
D14-0286	2.5"ID	2"OD	6	25	25	2.5	2.375	2	6	12
D14-0751	2.5"ID	2.5"OD	7	13	13	3.75"	9.25	2.75	6	12
D14-0775	2.5"ID	2.5"OD	7	31.5	31.5	11.5	14.5	2.5	6	12
D13-1614	2.5"ID	2.5"ID	8	24	24	2.75	2.75	1.25	6	12
D14-0850	2.5"ID	2.5"ID	8.5	17.75	17.75	2.75	2.75	3	2:30	12
D14-0976	2.5"ID	2.5"OD	9	17.75	18	2.75	2.75	3.75	2:15	12
D14-0905	2.5"ID	3"TP	9	23.75	24	3.25	3	3	10--2	12
D14-0112	2.5"ID	3"ID	9	25.625	26.625	4	4	3	9	12
D14-0545	2.5"ID	3"ID	10	25.5	25.5	5.5	3.5	3	12	1
D14-0939	2.5"ID	3.5"OD	10	25.5	25.5	3	4	3	6	2
D14-0943	2.5"ID	3.5"ID	10	25.5	25.5	5	4	3	1:30	12
D14-0572	2.5"ID	4"OD	10	26	26	4	3.5	3.5	2	12
D14-0740	2.5"ID	3"OD	10	26.5	26.5	3	2	2.75	12	9
D14-0878	2.5"OD	2.5"OD	8	13	13	4	4	1.652	6	12
D14-0807	2.5"OD	2.125"OD	8.5	17.875	17.875	5.5	10.5	2.75	6	12
D14-0674	2.5"OD	2"OD	9	27.5	27.5	4.25	3	4	6	12
D14-0014	2.5625"ID	3.5"OD	10	23.5	23.5	3	3	3.5	2--10	12
D14-0771	2.75"ID	2.75"OD	6	25.5	28.5	2.5		9	1:30-4:30	8
D14-0795	2.75"ID	3"OD	7	25	25	3	3	3	6	12
D14-0908	2.75"ID	3"ID	9	18	18	3	15	3	2	12
D13-0190	2.75"ID	2.75"ID	10	25	25	4.5	3	2.5	1:30	12
D14-0904	2.75"ID	3"ID	12	18	18	3	15	3	12	2
D14-0263	2.75"OD	4"OD	8.5	40	40	16	7	6	6	12
D14-0271	2.875"ID	4"ID	9	29.5	29.5	5	5	4.5	12	9
D14-0065	2.875"ID	2.875"OD	4.5X11	19.75	19.75	3	3	4	6	12
D14-0784	2.875"ID	2.875"OD	6x10	19.5	19.5	3	3	4.25	3	9
D14-0786	2.875"OD	2.875"OD	9	24	24	3	3	1	11:30	12
D14-0175	3"EL	3"ID	8.5	23	23	2.5	2.5	3.75	12	11:30
D14-0281	3"F	2"OD	7	25	25	8.375	3.5	3	6	12

mufflers

TYPE 10
SIDE IN
SIDE OUT

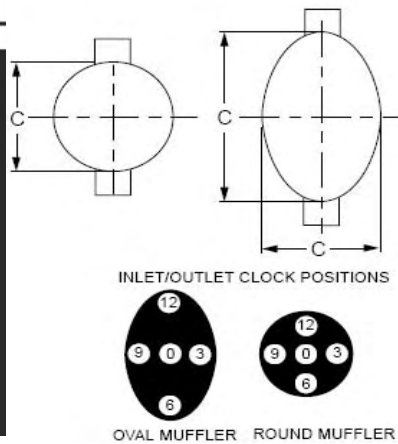

Note: All clock positions are determined by viewing the muffler from the end view, nearest the inlet.

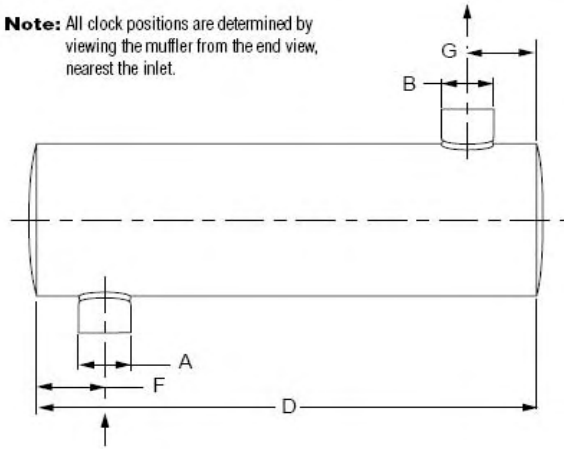

PART# NUMBER	A INLET SIZE	B OUTLET SIZE	C BODY SIZE	D BODY LENGTH	E OVERALL LENGTH	F INLET OFFSET	G OUTLET OFFSET	H INLET LENGTH	INLET CLOCK POSITION	OUTLET CLOCK POSITION
D14-0035	3"F	2.875"OD	10	23	23	3.75	3.5	2.78	6	12
D14-0955	3"F	3"TP	11	28.5	35	6.5	3	1.25	3	12:30
D14-0918	3"ID	3"ID	6	30	30	8.5	2	3"	6	12
D14-0672	3"ID	3.5"OD	7	24.5	24.5	2.625	3	2.25	5--1	11--7
D14-0974	3"ID	3"ID	8	18	18	5	5	3	12	6
D14-0232	3"ID	3.5"OD ASP	8	24.5	24.5	2.75	3	2	5--1	11--7
D14-0832	3"ID	3"OD	8.5	24	24	3	3	3	3	4
D14-0752	3"ID	3.5"ID	8.5	25	25	3.5	3.5	3	3	12
D14-0765	3"ID	3"ID	9	27	27	11.5	21.5	2.25	6	12
D14-0274	3"ID	4"ID	9	29.5	29.5	4.5	6	6	2:30	12
D14-0884	3"ID	4"OD	9	29.5	29.5	4.75	4	4.5	3	12
D13-0054	3"ID	4"ID	10	20	20	3.5	4	3	6	12
D14-0941	3"ID	3"TP	10	25	25	2.5	4	3	3	12
D14-0197	3"ID	3.5"OD	10	25.5	25.5	4	4	2.75	6	12
D14-0628	3"ID	3"ID	10	28	28	4	14	3	11	4:30--7:30
D14-0601	3"ID	3"OD	10	29	29	17	5	3	6	12
D14-0844	3"ID	4"OD	10	29.5	29.5	3.5	10	1.5	12	5
D14-0604	3"ID	4.5"ID	10	32	32	4	4.75	4	5--7	12
D14-0742	3"ID	3.5"OD	11	21.5	21.5	4	3.5	1.5	12	1:45
D14-0748	3"ID	3.5"OD	11	31	31	4.5	5.5	5	4	12
D14-0697	3"ID	3.5"ID	11	31.25	31.25	4.5	5.5	3	4	12
D14-0465	3"ID	3"ID	10DW	29.5	29.5	4	4	3	6	12
D14-0608	3"ID	3"ID	4.25X8.75	9.5	10	2.75	2.75	1.25	9	3
D14-0770	3"ID	2.5"OD	4.25X8.75	10	10	3	3	2	9	3
D14-0923	3"ID	3"ID	4.25X8.75	28	28	2.75	2.75	3	9	1:30
D14-0612	3"ID	3"OD	4.25X8.75	28.25	28.25	2	2	3.5	9	3
D14-0131	3"ID	3"ID	4.5X11	30.5	30.5	2	2	3	6	3
D14-0826	3"ID	3.125"OD	6x10	12.5	12.5	4	4	2.5	3	9
D14-0876	3"ID	3"OD	6x10	26.79	26.79	2.79	2.79	1.5	4:30	4:30
D14-0216	3"ID	3"ID	8.25X11.5	36	36	4.5	4.5	10	6	12
D14-0061	3"OD	3"OD ASP	6	27	27	3	3.125	12	6	12

mufflers

TYPE 10
SIDE IN
SIDE OUT

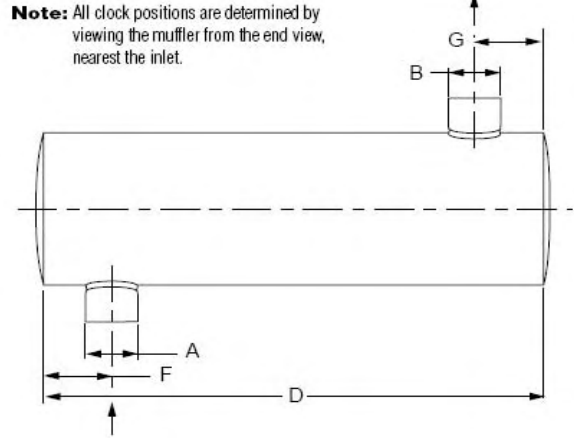
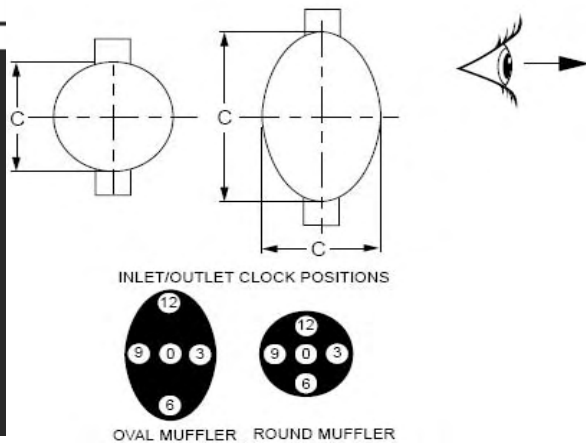

PART# NUMBER	A INLET SIZE	B OUTLET SIZE	C BODY SIZE	D BODY LENGTH	E OVERALL LENGTH	F INLET OFFSET	G OUTLET OFFSET	H INLET LENGTH	INLET CLOCK POSITION	OUTLET CLOCK POSITION
D13-1634	3"OD	3"OD	6	29	29	14.5	3.5	2.5	6	12
D14-0903	3"OD	3"OD	9	23	23	3	3	3	12	4
D14-0774	3"OD	3"OD	10	30	30	6.5	15	3	12	5:30-6:30
D14-0877	3"OD	3"ID	10	30	30	6.5	15	4	4:30	9
D14-0573	3"OD	4"OD	12	31	31	4	4	4	2:30	12
D14-0583	3.125"EL	4"ID	10	29.5	29.5	6	4	5	12	9:30
D14-0119	3.15"OD	3.54"OD	9	25.39	25.39	3.45	3.45	3	4:30	12
D14-0959	3.25"ID	3.5"OD	8.5	23	23	2.375	8.375	2.5	12	2:30
D14-0611	3.25"ID	3.5"TP	11	30	30	3.25	3.75	3.5	9:30	12
D14-0767	3.35"EL	3.50"OD	11	24	24	9.625	4.5	4	2:30-9:30	12
D14-0121	3.375"EL	3"OD	9	28.75	28.75	3	2.5	5	11	12
D14-0248	3.5"F	3.5"TP	12	28.5	28.5	5	6.5	2	9	12
D14-0100	3.5"F	3.5"OD	10x15	24	24	12	5	1.5	9	3
D14-0116	3.5"F	4"OD	10x15	36	36	18	5	1.75	3	9
D13-1606	3.5"ID	3.5"ID	8	23.5	23.5	2.75	15.5	3	12	2
D14-0053	3.5"ID	5"OD	8	33	33	7	17	3	3	6
D14-0639	3.5"ID	4"OD	10	22.5	22.5	3	3.75	4	12	2
D14-0998	3.5"ID	3"OD	10	23	23	3	3	2	12	2:30
D14-0947	3.5"ID	3.5"TP	11	25.5	25.5	8.5	3.5	6.5	3	12
D14-0593	3.5"ID	2.5"ID	11	25.75	25.75	3.75	3.5	3	6	12
D14-0791	3.5"ID	3.5"OD	11	27.5	27.5	4	4.5	3	11	3
D14-0165	3.5"ID	3.5"ID	11	31	31	4	5.25	3	1:30	12
D14-0858	3.5"ID	3.5"OD	6x10	21	21	3	2.75	3	3	6
D14-0685	3.5"ID	3.61"OD	8.25X11.5	24	24	3.125	3.375	3	6	12
D14-0481	3.5"ID	3.5"ID	8.25X11.5	32	32	4.75	5.75	3	3	3
D14-0707	3.5"ID	3.5"ID	8.25X11.5	36	36	3.5	3.5	4	9	3
D14-0523	3.5"OD	3"OD	10	22	22	8.75	4	4	6	12
D14-0491	3.5"OD	3.5"OD	11	30	30	6	3.5	3.5	9:45	12
D14-0220	3.5"OD	3.5"OD	11	40	40	2.75	2.75	6	6	12
D14-0919	3.5"OD	3.5"TP	8.25X11.5	29.5	29.5	3.25	3	4	6	12
D14-0264	3.75"ID	4"OD	11	31	31	4.25	5.5	3	1:30	12

mufflers

TYPE 10
SIDE IN
SIDE OUT

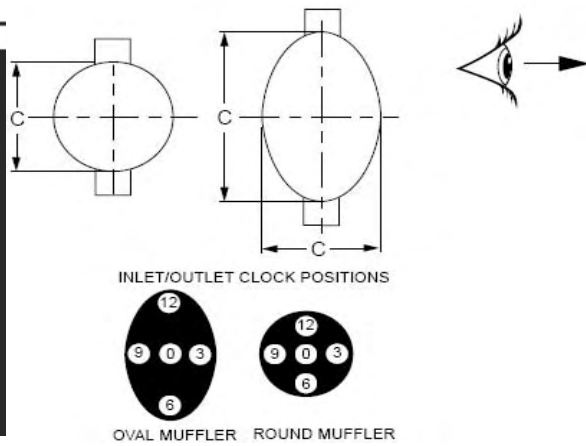

Note: All clock positions are determined by viewing the muffler from the end view, nearest the inlet.

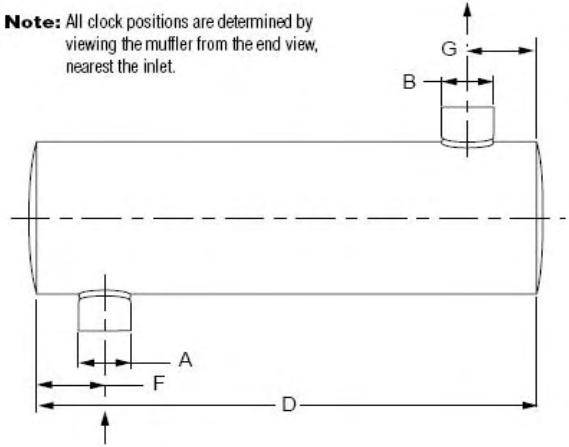

PART# NUMBER	A INLET SIZE	B OUTLET SIZE	C BODY SIZE	D BODY LENGTH	E OVERALL LENGTH	F INLET OFFSET	G OUTLET OFFSET	H INLET LENGTH	INLET CLOCK POSITION	OUTLET CLOCK POSITION
D14-0594	3.75"ID	3.5"ID	11	31	31	4.25	5.5	3	2	12
D14-0899	3.75"ID	3.5"OD	11	36	36	3.5	3.5	2.75	6	12:45
D14-0020	3.75"OD	4"OD	12	34	34	5.5	17	4	9	12
D14-0710	3.825"ID	3.29"ID	10	27	27	4.5	3.89	3	4	12
D14-0252	3.875"ID	3.25"ID	10x15	29.5	29.5	4.75	8.5	3	9	2--10
D14-0632	4"EL	4"OD	10	26	26	8	18	3	2	12
D13-7286	4"EL	4"ID	10x15	32	32	5.5	26.5	8	6	12
D14-0000	4"F	5.8"OD	10	38	38	12.625	5.33	1.75	7--3	12
D14-0868	4"F	4.5"OD	10x15	36	36	18	5	1.625	9	3
D14-0162	4"ID	4"ID	9	21	21	5	5	3	6	12
D14-0222	4"ID	4"ID	9	27	27	4.5	5.5	4.5	6	12
D14-0619	4"ID	4"OD	10	25	25	7	5	1.75	6	12
D14-0476	4"ID	4"OD	10	27	27	4.5	4	3	12	8
D14-0859	4"ID	4"ID	10	28	28	4.5	4.5	3	6	12
D14-0854	4"ID	4.125"OD	10	30.5	30.5	4.25	7.625	2.5	8	12
D14-0964	4"ID	4.132"OD	10	30.5	31	4.25	8.25	2.375	4	12
D14-0135	4"ID	5"ID	10	35	35	7	11	4	6	12
D14-0218	4"ID	5"ID	10	36	36	3	3.5	3	6	12
D14-0677	4"ID	4"OD	10	44	44	4	4.5	3	12	3
D13-1590	4"ID	4"ID	11	26	26	4	4	3	6	12
D13-1517	4"ID	5"OD	11	32	32	3.5	4.5	3	12	12
D13-0035	4"ID	4"OD	11	36	36	4	13.5	3	12	10:30
D13-0036	4"ID	4"ID	11	36	36	4.5	17.5	3	12	10:30
D13-0091	4"ID	5"OD	11	36	36	19	8	3	1:30-4:30	10:30
D13-0159	4"ID	5"OD	11	36	36	17.5	4.5	3	12	10:30
D13-0165	4"ID	4"ID	11	36	36	5	18	3	12	3
D13-0188	4"ID	5"OD	11	36	36	19	7	4	12:30-5:30	9
D13-1509	4"ID	4"OD	11	36	36	4	7	3	12	9
D13-1523	4"ID	4"OD	11	36	36	4	18.5	4	12	10
D13-2085	4"ID	4"OD	11	36	36	4	13.5	3	12	1:30
D13-7706	4"ID	4"OD	11	36	36	4.3	6.8	3.1	12	9

mufflers

TYPE 10
SIDE IN
SIDE OUT

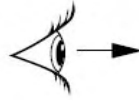
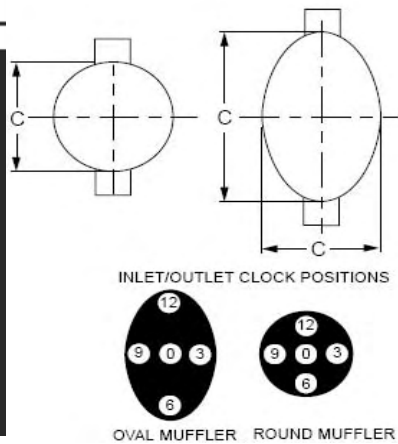

Note: All clock positions are determined by viewing the muffler from the end view, nearest the inlet.

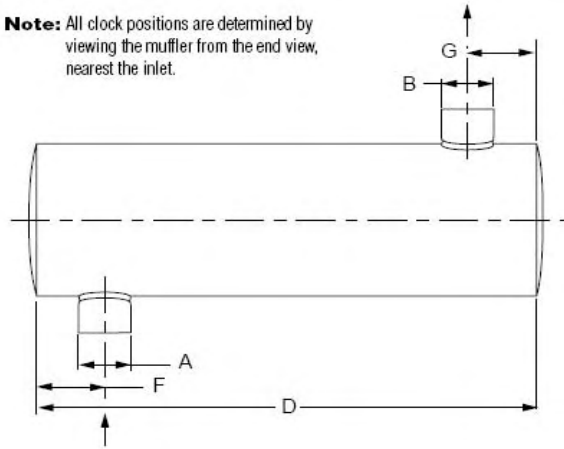

PART# NUMBER	A INLET SIZE	B OUTLET SIZE	C BODY SIZE	D BODY LENGTH	E OVERALL LENGTH	F INLET OFFSET	G OUTLET OFFSET	H INLET LENGTH	INLET CLOCK POSITION	OUTLET CLOCK POSITION
D14-0948	4"ID	4"OD	11	36	36	4	9	3	6	3
D14-0890	4"ID	5"OD	12	29.5	29.75	8.5	26	3.5	4:30	6
D14-0970	4"ID	3.5"OD	12	31.5	31.5	4.5	6	2.25	12	11
D14-0618	4"ID	4"OD	12	34	34	5.75	5	6.75	12	4
D14-0642	4"ID	4"OD	12	34	34	5.875	5.875	7	12	4:30
D14-0992	4"ID	4"ID	12	34	34	3.75	3.75	6.75	12	2
D14-0881	4"ID	4.5"OD	12	34.25	34.5	7	4	5	6:30	3
D14-0823	4"ID	4"ID	10.125DW	46	46	4.5	5.5	3	12	6
D14-0813	4"ID	3.5"ID	10DW	40	40	4.5	4.5	3	12	9
D14-0387	4"ID	4"ID	10x15	28	28	14	14	3	3	9
D14-0887	4"ID	4.125"OD	10x15	28.5	31.5	4.5	4.5	2.25	6	12
D14-0902	4"ID	4"OD	10x15	35.25	35.5	4.125	4.75	1.25	10	4
D14-0092	4"ID	4"OD	10x15	35.5	35.5	4	5	3	2:30--9:30	7:30--4:30
D14-0922	4"ID	4"OD	10x15DW	35.5	35.5	4	5	3	7:30	1:30
D13-1549	4"ID	4"OD	4.25X8.75	25	25	3	3	3	6	12
D14-0019	4"ID	4"OD	8.25X11.5	23	23	4	3.5	2	6	12
D14-0174	4"ID	3.5"OD	8.25X11.5	30	30	4	3.5	3	12	6
D14-0160	4"ID	3.5"OD	8.25X11.5	32	32	4.5	4.5	2.5	9	3
D14-0194	4"OD	4"OD	10	25	25	4	4	4	6	12
D14-0203	4"OD	3.5"OD	11	23.5	23.5	5.5	8.75	2	12	2
D14-0510	4"OD	3.5"OD	11	31.25	31.25	3	3	2.75	12	11--3
D14-0982	4"OD	4"OD	11	34	34	6.75	7.5	5	1:30	12
D13-1537	4"OD	4"ID	11	36	36.25	4	7	4.5	6	3
D14-0660	4"OD	3.5"OD	11	36	36	3.5	3.5	3	12	11
D14-0540	4"OD	4"ID	12	34.5	34.5	6	4.5	3.5	12	10
D14-0897	4"OD	5"OD	12	34.5	34.75	4.5	5	4	12	10:30
D13-1559	4"OD	4"OD	10x15	25	25	3.25	12	4	6	12
D14-0627	4"OD	5"OD	10x15	27.5	27.5	2.75	20	3	6	3
D14-0891	4"OD EL	4"OD	11	34	34.25	3	14.5	5.75	4	12
D14-0857	4.25"ID	4.5"OD	12	34	34	6.75	3.5	5	3	12
D14-0893	4.25"ID	4.25	12	36	36	3.375	3.375	10	6	12

mufflers

TYPE 10
SIDE IN
SIDE OUT

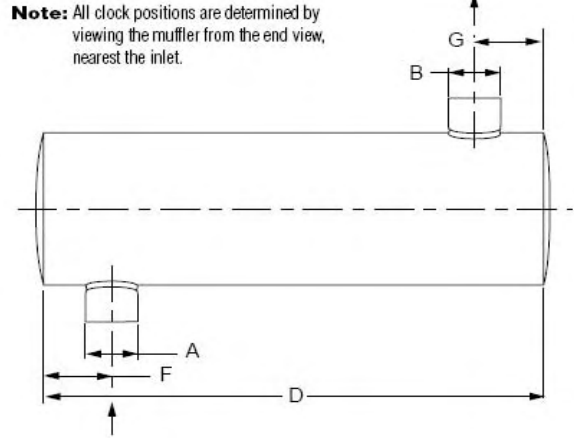
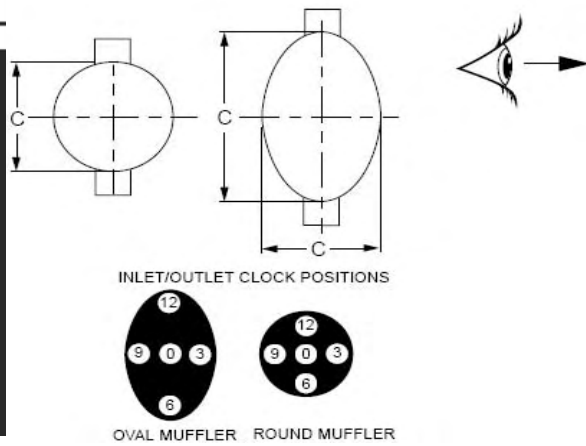

PART# NUMBER	A INLET SIZE	B OUTLET SIZE	C BODY SIZE	D BODY LENGTH	E OVERALL LENGTH	F INLET OFFSET	G OUTLET OFFSET	H INLET LENGTH	INLET CLOCK POSITION	OUTLET CLOCK POSITION
D14-0030	4.375"ID	5.125"OD	10x15	27.5	27.5	6.375	7	2	9	3
D14-0910	4.5"F	6"OD	12	36	36	12.5	4	1	7:30	12
D14-0990	4.567"FL	4.5"OD	12DW	29.5	29.5	5.625	4.75	2	7:30	12
D14-0676	5"FL	4.5"FL	18	27.5	27.5	4.25	5.5	1.5	6	11:15
D13-1110	5"ID	5"OD	10	32	32	4	5	3	6	12
D14-0451	5"ID	5"ID	10	32	32	4.5	4.5	3	6	12
D14-0522	5"ID	5"ID	10	32.5	32.5	5.5	4.5	3	6	12
D14-0621	5"ID	5"ID	10	32.5	32.5	3.5	5.25	3	6	12
D14-0745	5"ID	6"OD ASP	10	33	33	3.5	4	2.5	12	3
D13-1062	5"ID	5"OD	11	34.5	34.5	3.5	11	2.5	6	3
D14-0138	5"ID	5"ID	11	36	36	7	4	6	12	3
D14-0461	5"ID	5"ID	11	48	48	6	6	3	9	12
D13-1143	5"ID	5"ID	12	28	28	5.5	12.5	3	6	6
D14-0527	5"ID	5"ID	12	42	42	5	5	3	6	9
D13-1029	5"ID	5"ID	12	48	48	5.5	34.5	3	12	11
D14-0058	5"ID	5"ID	16	25	25	3.5	3.5	3	2	9
D14-0911	5"ID	5"ID	10x15	26.5	26.5	4.5	4.5	3.5	8	2
D14-0653	5"ID	5"OD	10x15	30	30	4.5	24.25	1.5	3:30-8:30	10:30-1:30
D13-0074	5"ID	5"ID	10x15	32	32	3.5	3.5	2.5	6	3
D13-1113	5"ID	5"ID	10x15	32	32	4	5	3	12	6
D14-0025	5"ID	4"ID	10x15	34	34	5	5	1	9	3
D13-1091	5"ID	5"ID	10x15	38	38	13	13	3	2	12
D14-0552	5"ID	5"OD	10x15DW	33	33	3.5	6	2	6	12
D13-0057	5"OD	4"OD	11	31.5	31.5	6.5	16.5	5	3	12
D13-0031	5"OD	5"ID	10x15	27	27	2.75	2.75	5	6	12
D14-0454	5"OD	6"OD	10x15	29	29	4	6	3	2	8
D14-0874	5"OD	5"ID	10x15	30	30	5	4	7.5	12	6
D13-1047	5"OD	5"OD	10x15	36	36	6.5	4.5	4	3	12
D14-0953	5.125"ID	6"ID	16	53	53	7.5	6.5	3	6	12
D14-0278	5.5"OD	6"OD	12	44	44	5	4	5	6	12
D14-0793	6"ID	5"ID	10	32	32	5.5	12.5	3	12	6

mufflers

TYPE 10
SIDE IN
SIDE OUT

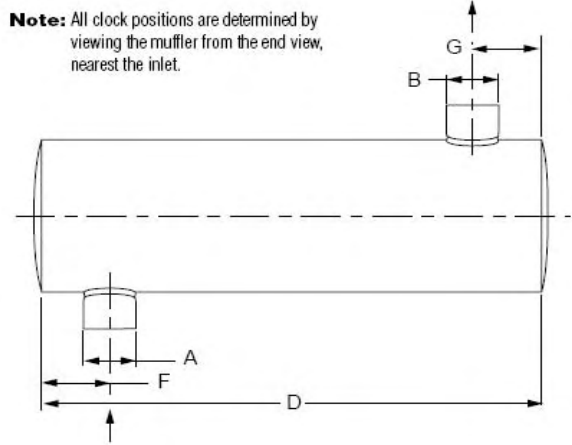
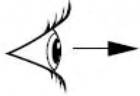
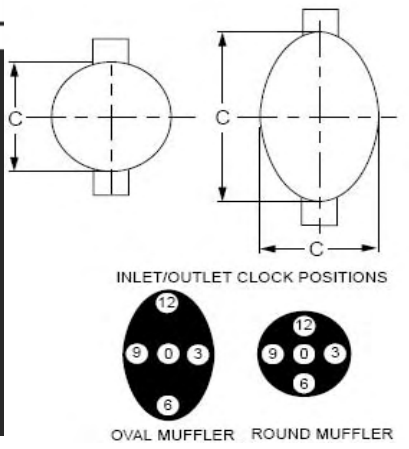

PART# NUMBER	A INLET SIZE	B OUTLET SIZE	C BODY SIZE	D BODY LENGTH	E OVERALL LENGTH	F INLET OFFSET	G OUTLET OFFSET	H INLET LENGTH	INLET CLOCK POSITION	OUTLET CLOCK POSITION
D14-0702	6"ID	6"OD	10x15	44	44	22	6	3.5	8--4	3
D14-0733	8"ID	8"OD	12	36	36	8	8	6	6	12
D14-0747	8"ID	8"ID	10x15	44	44	10	10	3	3	9